

GPA-25 Palletizing Robot

with exchange coupler for vacuum and fork gripper

6-axis-robot for dynamic palletizing and depalletizing on up to 2 pallets

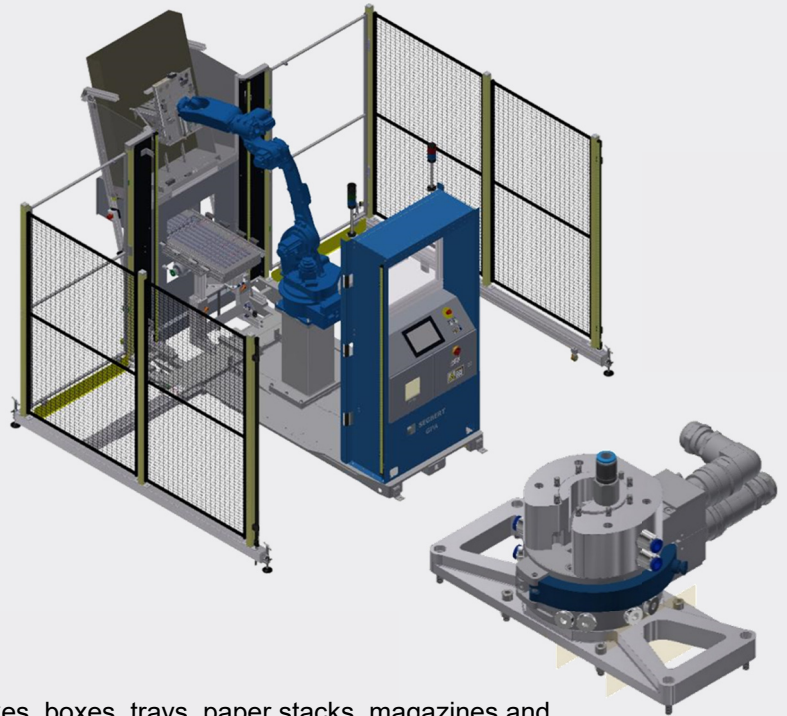

Technical Specifications

Products	Cardboard boxes, boxes, trays, paper stacks, magazines and other packages, optionally with slip sheet or cardboard magazine	
System	6-axis-robot	
Product width	Vacuum gripper 100 – 400 mm, optionally also bigger	Fork gripper 150 – 260 mm
Product length	100 – 600 mm	150 – 380 mm, back length
Product height	50 – 400 mm, other heights upon request	35 – 230 mm
Load capacity	max. 19 kg*	11 kg*
Pallet height	max. approx. 1800 mm, incl. pallet*	approx. 1600 mm, incl. pallet *
Empty pallet height	130 mm (min.) – 150 mm (max.)	140 mm (min.) – 160 mm (max.)
Speed	max. 11 cycles/min.*	6 cycles/min.*
Pallet formats	800 x 1200 mm, 1000 x 1200 mm, 40 x 48", 1165 x 1165 mm, 45 x 45" (other pallet formats possible)	
Mechanical construction	compact aluminum screw construction, steel welded construction	
Drive	6 controlled Servo axes	
Voltage	3 x 380 – 480 VAC, 50/60 Hz	
Power consumption	approx. 3 kVA	
Fuse	3 x 16 A, slow-blow fuse+	
	Special NAS versions for North America conform to the ANSI standard. The UL standard is not met.	
Air pressure	min. 6 bar	
Air consumption	depending on gripping device	
Control	IPC with RobAdmin palletizing program as a configuration interface for setting the package and pallet sizes and the layer patterns	

*The data given is interdependent with product dimensions, pallet format, pallet height, speed, gripping tool, column height and number of slip sheets.

Color scheme as shown (see above).

Gutenbergstraße 16
D-48683 Ahaus

Telefon +49 (0) 25 61/95 04-0
Telefax +49 (0) 25 61/95 04-20
Mail segbert@segbert.com

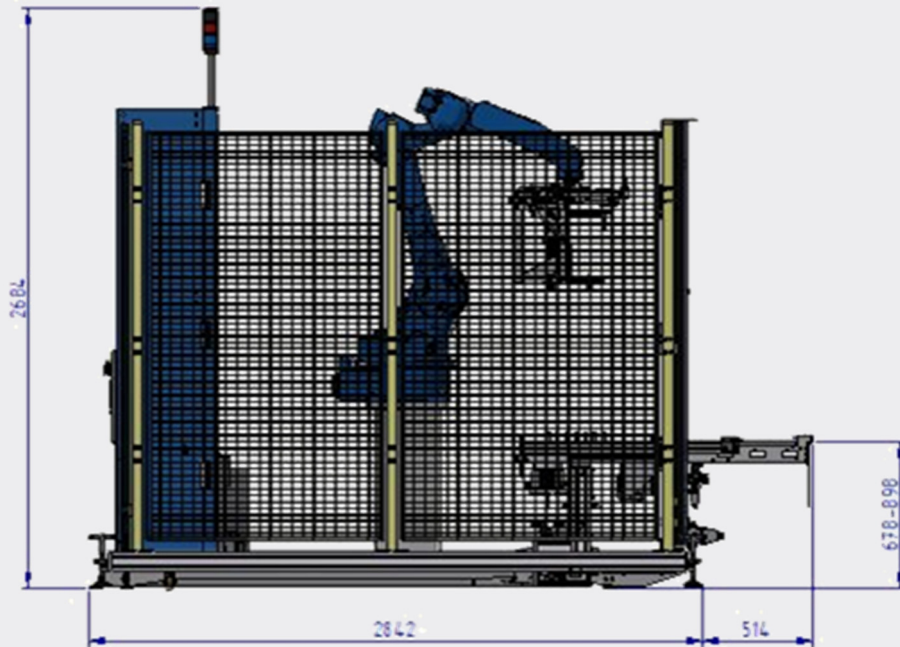

Transport dimensions

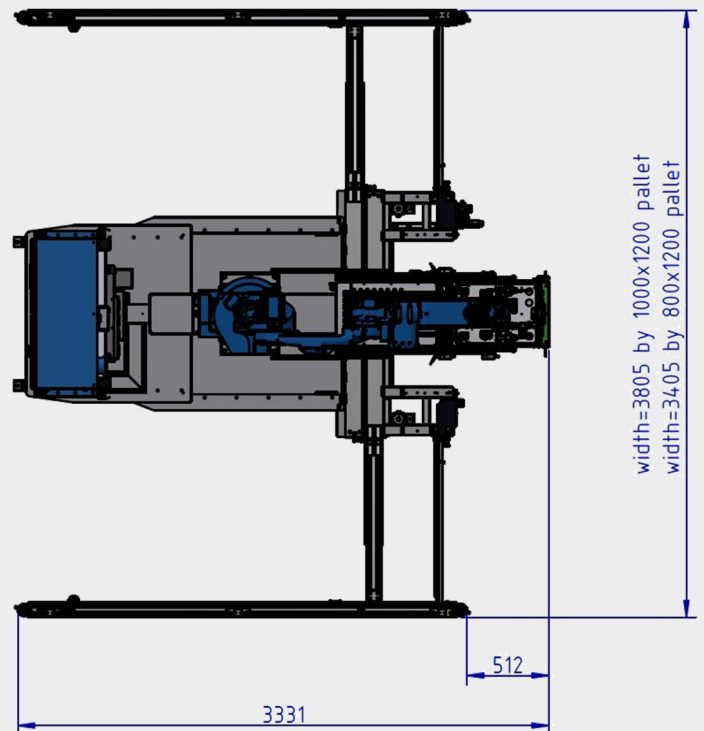
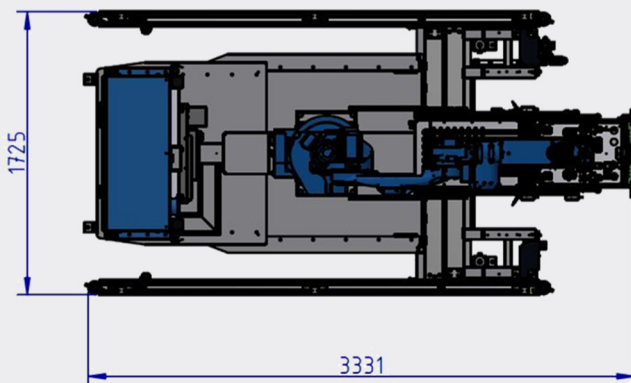

Volksbank Gronau Ahaus eG IBAN: DE33 4016 4024 0602 0192 00 BIC: GENODEM1GRN

Sitz der Gesellschaft: Ahaus Registergericht: Coesfeld, HRA 2848 UStID.: DE123788344 Steuernummer: 301/5750/0035
Komplementär: Segbert Verwaltungsgesellschaft mbH Sitz: Ahaus Registergericht: Coesfeld, HRB 4251
Geschäftsführer: Klaus Segbert